

High Productivity Cooking Electric Tilting Boiling Pan, 60lt , Freestanding

ITEM # _____

MODEL # _____

NAME # _____

SIS # _____

AIA # _____

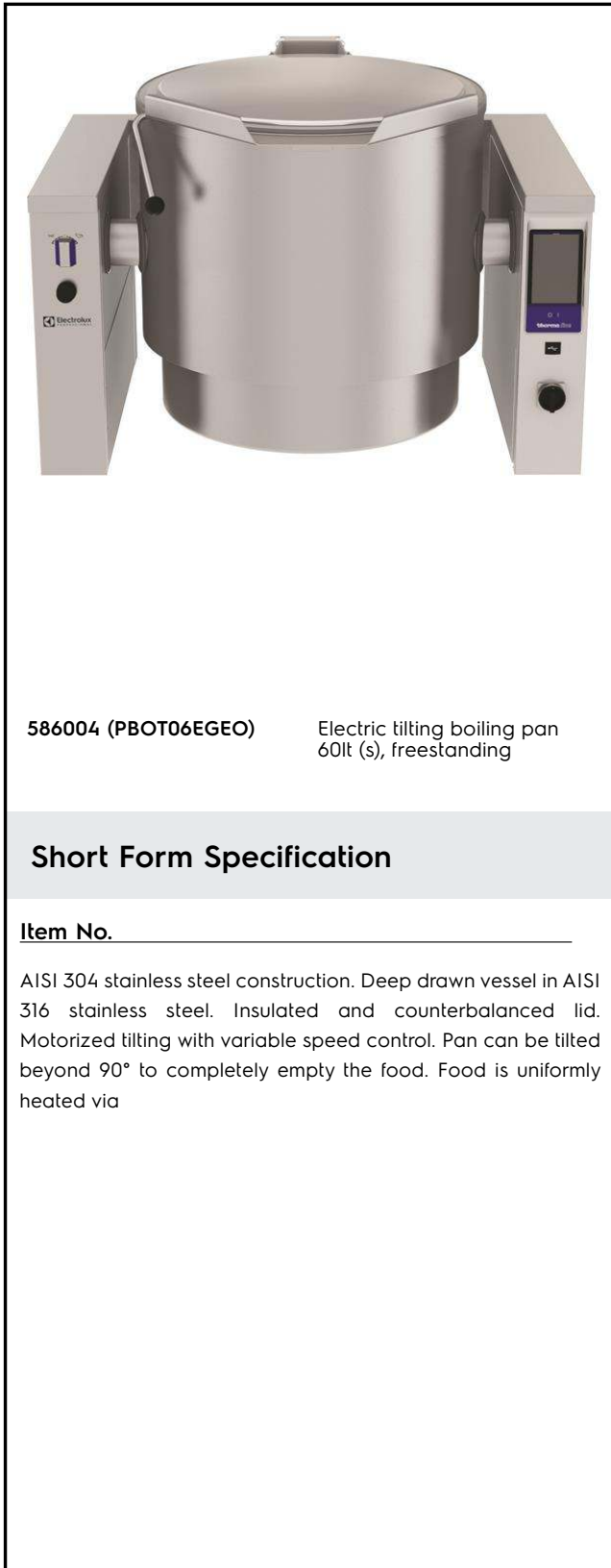

586004 (PBOT06EGEO) Electric tilting boiling pan
 60lt (s), freestanding

Short Form Specification

Item No. _____

AISI 304 stainless steel construction. Deep drawn vessel in AISI 316 stainless steel. Insulated and counterbalanced lid. Motorized tilting with variable speed control. Pan can be tilted beyond 90° to completely empty the food. Food is uniformly heated via

Main Features

- Kettle is suitable to boil, steam, poach, braise or simmer all kinds of produce.
- Kettle is jacketed up to 134 mm from upper rim.
- Isolated upper well rim avoids risk of harm for the user.
- Ergonomic vessel dimensions, with a large diameter and shallow depth facilitates stirring and gentle food handling.
- Edge of the large pouring lip can be equipped with a strainer (option).
- Motorized, variable pan tilting with "SOFT STOP". Tilting and pouring speeds can be precisely adjusted. Pan can be tilted over 90° to facilitate pouring and cleaning operations.
- Built in temperature sensor to precisely control the cooking process.
- USB connection to easily update the software, upload/download recipes and download HACCP data.
- IPX6 water resistant.
- Max pressure of inner jacket at 1.7 bar; minimum working pressure at 1 bar. Allows temperature control between 50 and 110°C.

Construction

- Cooking vessel in 1.4435 (AISI 316L) stainless steel featuring directional pouring lip. Double-jacket in 1.4404 (AISI 316L) stainless steel designed to operate at a pressure of 1.5 bar.
- External panelling and internal frame made of 1.4301 (AISI 304) stainless steel.
- Double-lined insulated lid in 1.4301 (AISI 304) stainless steel mounted on the cross beam of the unit, counterbalanced by a hinge that remains open in all positions.
- Safety valve avoids overpressure of the steam in the double jacket.
- Safety thermostat protects against low water level in the double jacket.
- Ergonomic and user friendly thanks to the high tilting position and the pouring lip design which allow to easily fill containers.
- Water mixing tap is available as optional accessory to make water filling and pan cleaning easier.
- Front-mounted inclined led "TOUCH" control panel with recessed deep drawn casing, features self-explanatory display functions which guide operator throughout the cooking process: simultaneous display of actual and set temperature as well as set cooking ti
- Minimised presence of narrow gaps for easier cleaning of the sides to meet the highest hygiene standards.
- Can be prearranged for energy optimisation

APPROVAL: _____

or external surveillance systems (optional).

- Possibility to store recipes in single or multiphase cooking process, with different temperature settings.
- 98% recyclable by weight; packaging material free of toxic substances.
- GuideYou Panel - activated by the user via settings - to easily follow the multiphase recipes, granting a proper and controlled cooking and a better appliance optimization.
The system will provide maintenance reminders, in line with ESSENTI
- Highly-visible and bright led TOUCH control panel features user-friendly icons and intuitive self-explanatory command options. Display visualizes:
 - Actual and set temperature
 - Set and remaining cooking time CHAR(13)CHAR (

User Interface & Data Management

- Connectivity ready for real time access to connected appliances from remote and data monitoring (requires optional accessory - contact the Company for more details).

Optional Accessories

- | | | |
|---|------------|--------------------------|
| • Strainer for 40 and 60lt tilting boiling pans | PNC 910001 | <input type="checkbox"/> |
| • Basket for 40 and 60lt boiling pans (diam. 480mm) | PNC 910021 | <input type="checkbox"/> |
| • Base plate for 60lt tilting boiling pans | PNC 910031 | <input type="checkbox"/> |
| • Measuring rod for 60lt tilting boiling pans | PNC 910042 | <input type="checkbox"/> |
| • Strainer for dumplings for 40 and 60lt tilting boiling pans | PNC 910052 | <input type="checkbox"/> |
| • Scraper for dumpling strainer for boiling and braising pans | PNC 910058 | <input type="checkbox"/> |
| • Strainer rod for stationary round boiling pans | PNC 910162 | <input type="checkbox"/> |
| • Stainless steel plinth for tilting units - against wall - factory fitted | PNC 911417 | <input type="checkbox"/> |
| • Stainless steel plinth for tilting units - freestanding - factory fitted | PNC 911447 | <input type="checkbox"/> |
| • Bottom plate with 2 feet, 100mm (height 800mm). To be ordered as special - factory fitted | PNC 911929 | <input type="checkbox"/> |
| • Food tap strainer for tilting boiling pans | PNC 911966 | <input type="checkbox"/> |
| • C-board (length 1100mm) for tilting units - factory fitted | PNC 912183 | <input type="checkbox"/> |
| • POWER SOCKET CEE-16A / 380V BUILT-IN | PNC 912468 | <input type="checkbox"/> |
| • POWER SOCKET CEE-32A / 380V BUILT-IN | PNC 912469 | <input type="checkbox"/> |
| • Power socket Schuko typ-23, 16A/230V, built-in version | PNC 912470 | <input type="checkbox"/> |
| • Power socket Swiss typ-23, 16A/230V, built-in version | PNC 912471 | <input type="checkbox"/> |

- | | | |
|--|------------|--------------------------|
| • Power socket Swiss typ-23, 16A/380V, built-in version | PNC 912472 | <input type="checkbox"/> |
| • Power Socket, SCHUKO, built-in, 16A/230V, IP55, black - factory fitted | PNC 912473 | <input type="checkbox"/> |
| • Power Socket, CEE16, built-in, 16A/230V, IP67, blue-white - factory fitted | PNC 912474 | <input type="checkbox"/> |
| • Power Socket, TYP23, built-in, 16A/230V, IP54, blue - factory fitted | PNC 912475 | <input type="checkbox"/> |
| • Power Socket, SCHUKO, built-in, 16A/230V, IP54, blue - factory fitted | PNC 912476 | <input type="checkbox"/> |
| • Power Socket, TYP25, built-in, 16A/400V, IP54, red-white - factory fitted | PNC 912477 | <input type="checkbox"/> |
| • Panelling for plinth recess (depth from 70 to 270mm) for tilting units - factory fitted (Deutschland, Austria, Switzerland) - factory fitted | PNC 912479 | <input type="checkbox"/> |
| • Manometer for tilting boiling pans - factory fitted | PNC 912490 | <input type="checkbox"/> |
| • Connecting rail kit for appliances with backsplash, 900mm | PNC 912499 | <input type="checkbox"/> |
| • Connecting rail kit, 900mm | PNC 912502 | <input type="checkbox"/> |
| • Automatic water filling (hot and cold) for tilting units - to be ordered with water mixer - factory fitted | PNC 912735 | <input type="checkbox"/> |
| • Kit energy optimization and potential free contact - factory fitted | PNC 912737 | <input type="checkbox"/> |
| • Rear closing kit for tilting units - against wall - factory fitted | PNC 912749 | <input type="checkbox"/> |
| • Rear closing kit for tilting units - island type - factory fitted | PNC 912755 | <input type="checkbox"/> |
| • Lower rear backpanel for tilting units, island type | PNC 912767 | <input type="checkbox"/> |
| • Mainswitch 25A, 4mm ² - factory fitted | PNC 912773 | <input type="checkbox"/> |
| • Spray gun for tilting units - freestanding (height 800mm) - factory fitted | PNC 912777 | <input type="checkbox"/> |
| • Food tap 2" for tilting boiling pans (PBOT) - factory fitted | PNC 912779 | <input type="checkbox"/> |
| • Emergency stop button - factory fitted | PNC 912784 | <input type="checkbox"/> |
| • Connecting rail kit, right | PNC 912975 | <input type="checkbox"/> |
| • Connecting rail kit, left | PNC 912976 | <input type="checkbox"/> |
| • Connecting rail kit for appliances with backsplash, right | PNC 912981 | <input type="checkbox"/> |
| • Connecting rail kit for appliances with backsplash, left | PNC 912982 | <input type="checkbox"/> |
| • - NOT TRANSLATED - | PNC 913554 | <input type="checkbox"/> |
| • - NOT TRANSLATED - | PNC 913555 | <input type="checkbox"/> |
| • - NOT TRANSLATED - | PNC 913556 | <input type="checkbox"/> |
| • - NOT TRANSLATED - | PNC 913557 | <input type="checkbox"/> |
| • - NOT TRANSLATED - | PNC 913567 | <input type="checkbox"/> |
| • - NOT TRANSLATED - | PNC 913568 | <input type="checkbox"/> |
| • CONNECTIVITY KIT FOR PROTHERMETIC BOILING & BRAISING (ECAP) | PNC 913577 | <input type="checkbox"/> |

Front

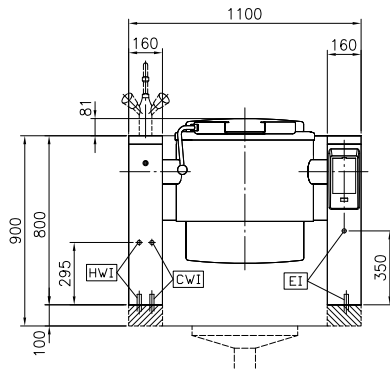

Side

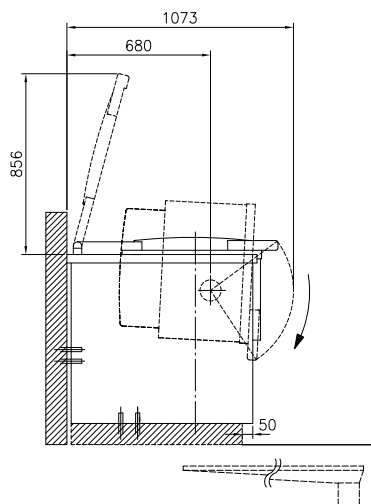

CWI = Cold Water inlet 1 (cleaning)
 EI = Electrical inlet (power)
 HWI = Hot water inlet

Top

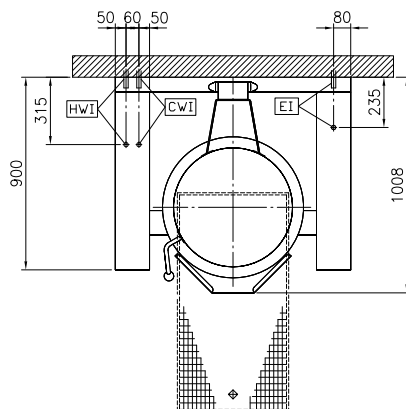

Electric

Supply voltage: 400 V/3N ph/50/60 Hz
Total Watts: 12.2 kW

Installation:

Type of installation: FS on concrete base; FS on feet; On base; Standing against wall

Key Information:

Working Temperature MIN: 50 °C
Working Temperature MAX: 110 °C
Vessel (round) diameter: 579 mm
Vessel (round) depth: 385 mm
External dimensions, Width: 1100 mm
External dimensions, Depth: 900 mm
External dimensions, Height: 800 mm
Net weight: 170 kg
Configuration: Round; Tilting
Net vessel useful capacity: 60 lt
Tilting mechanism: Automatic
Double jacketed lid: ✓
Heating type: Indirect

Energy Consumption

Standard:
Item heated: 0 lt
Heat up temperature: From 0°C to 0°C
Heat up time: 0 min

Sustainability

Energy consumed in heat up phase: 0
Energy efficiency: 0 %